



AZO robot application for API production

Philippe Steinbusch



RAYA 2024 Finalist Event



AZO Robot application (API Production)



Improved ergonomics



High precision weighing

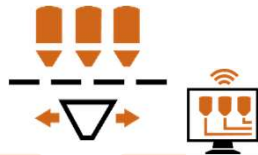

Automated production
24/7 availability

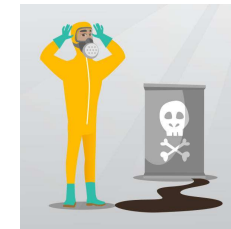

Containment & ATEX requirements



Batch traceability



Batch integrity (CIP)



Validated system
GMP compliant software

AZO Robot application (API Production)



AZO Robot application (API Production)



Introduction of raw materials

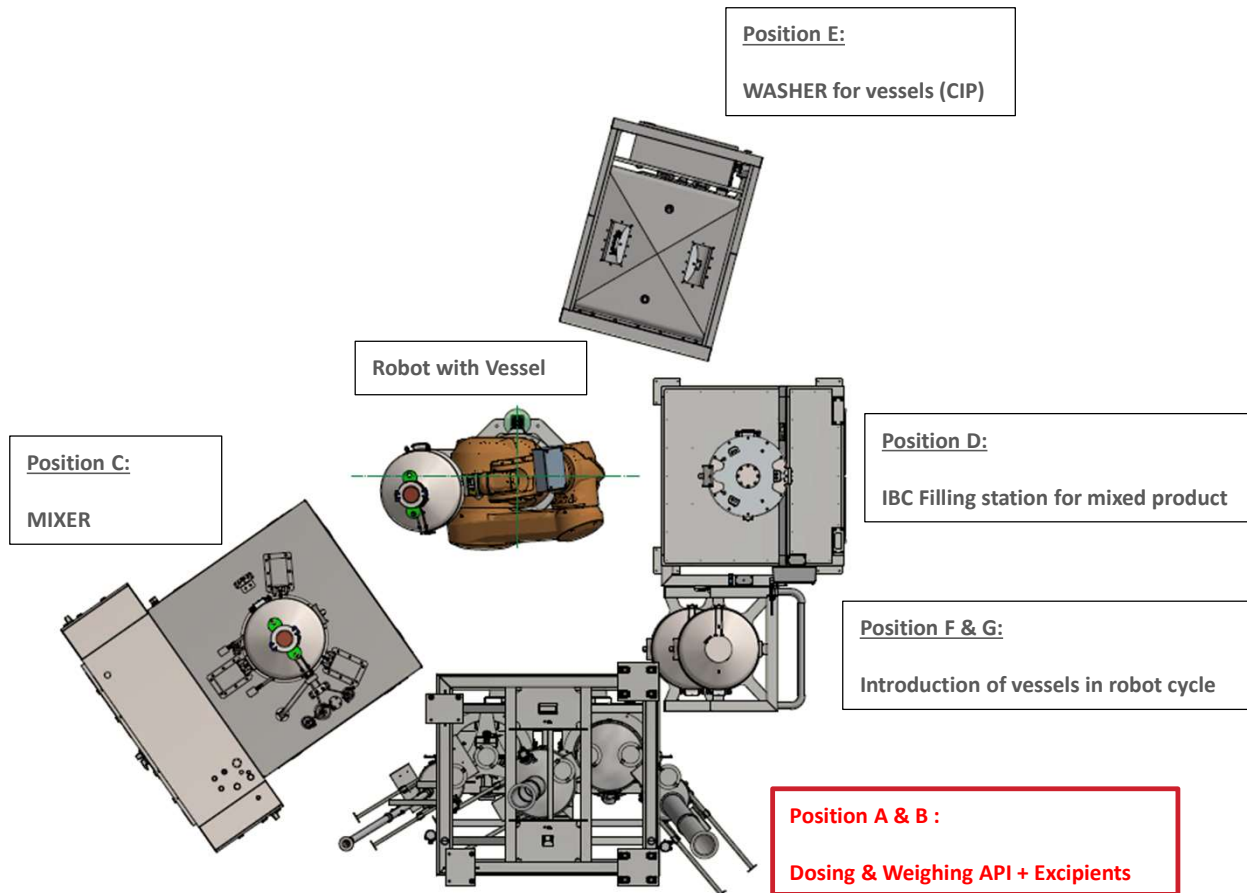

AZO Robot application (API Production)



Introduction of raw materials

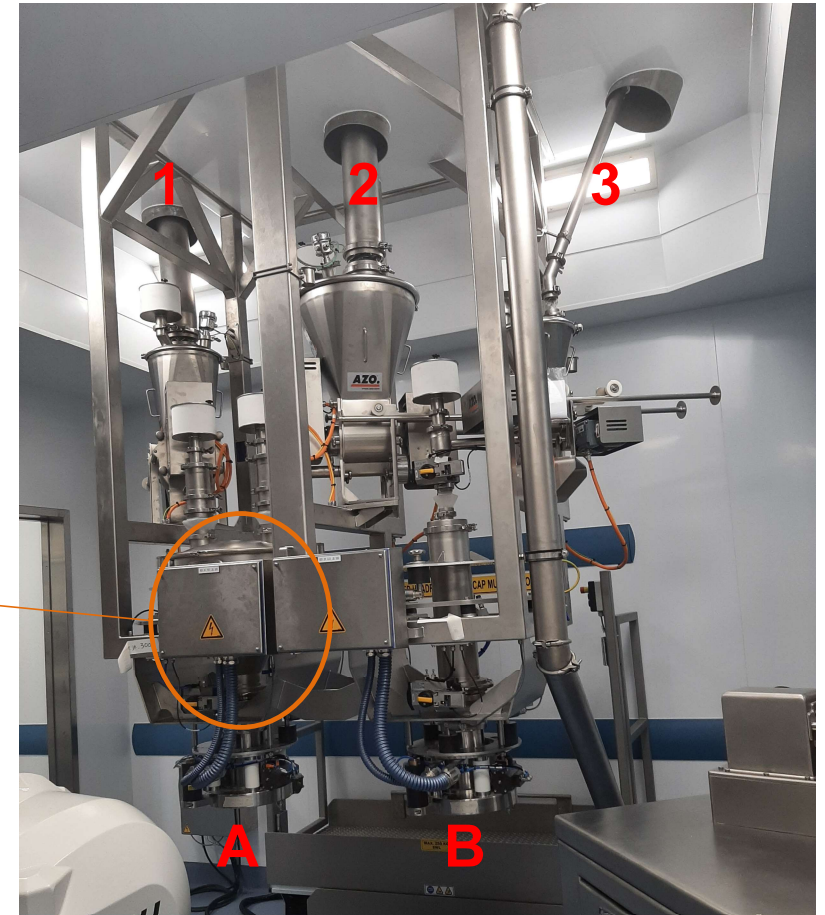
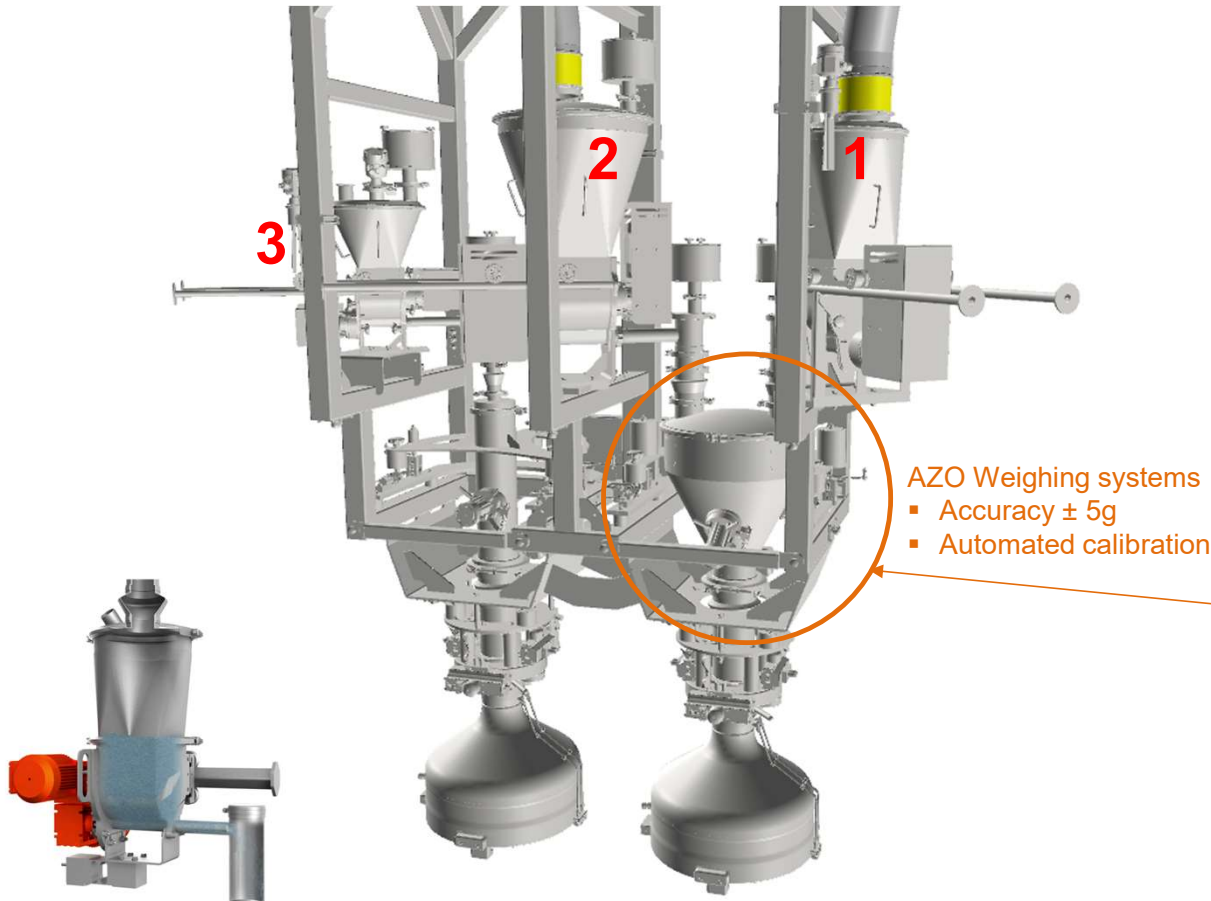

AZO Robot application (API Production)



AZO Robot application (API Production)

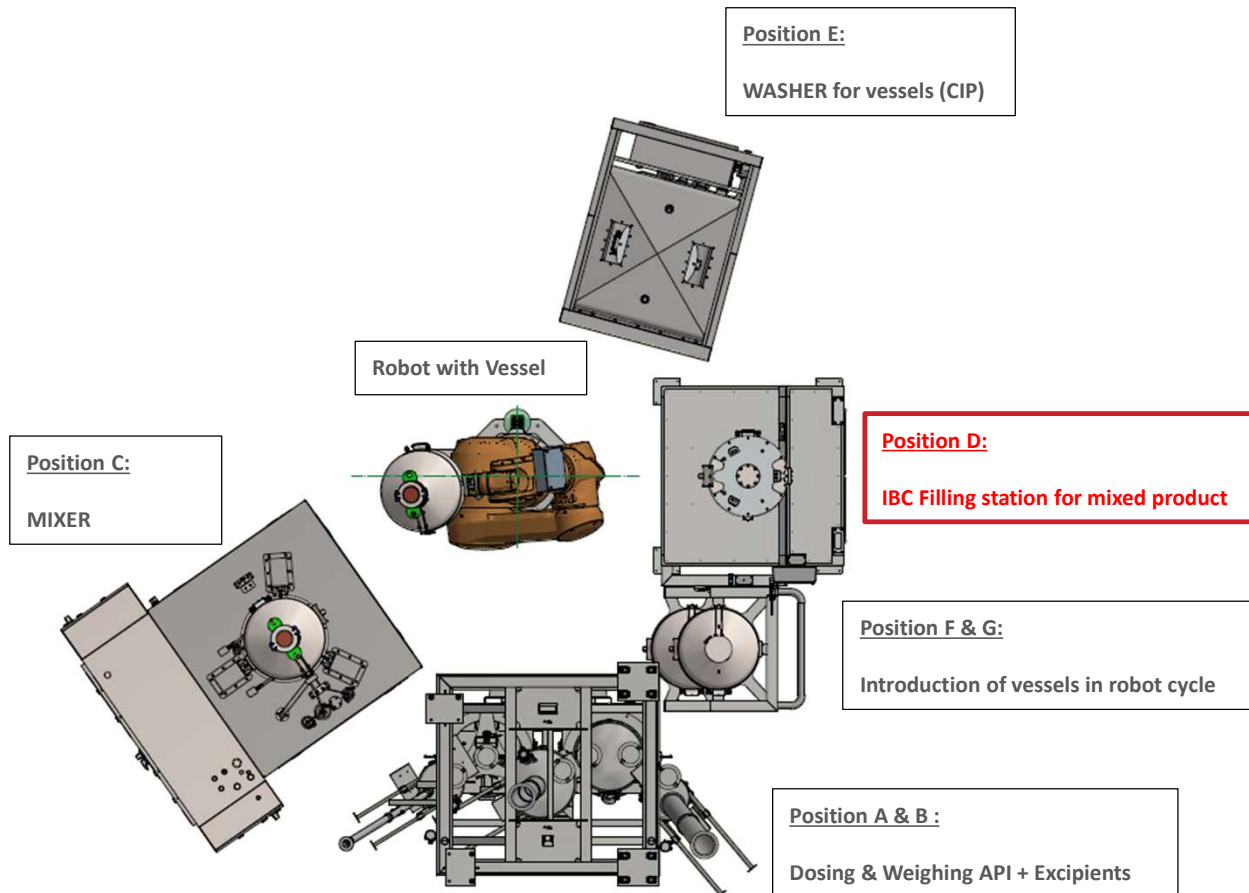

Filling of finished product into IBC

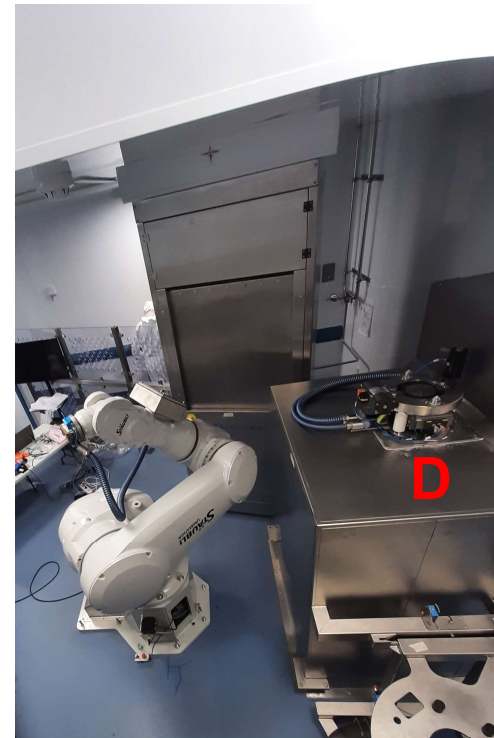

AZO Robot application (API Production)

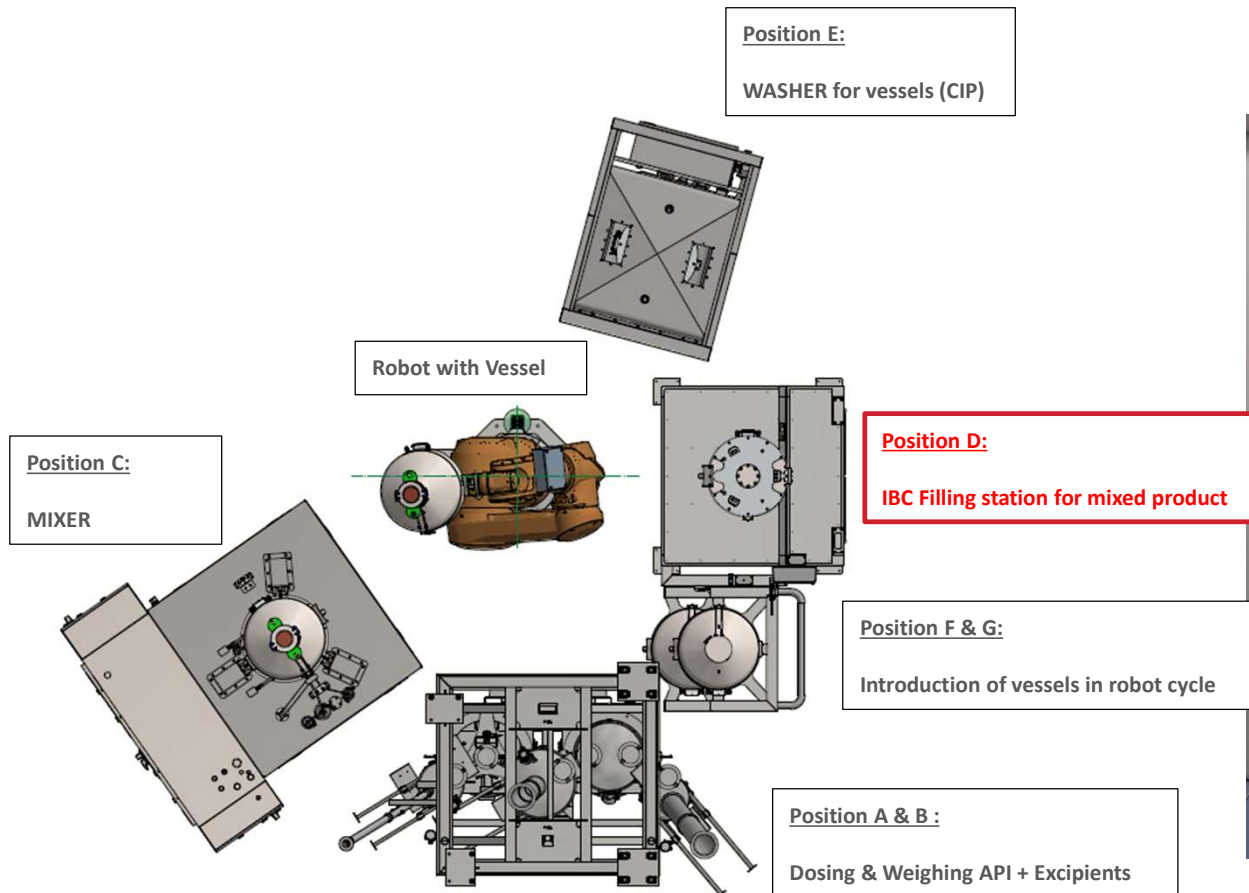

Filling of finished product into IBC



Weighing scale

AZO Robot application (API Production)

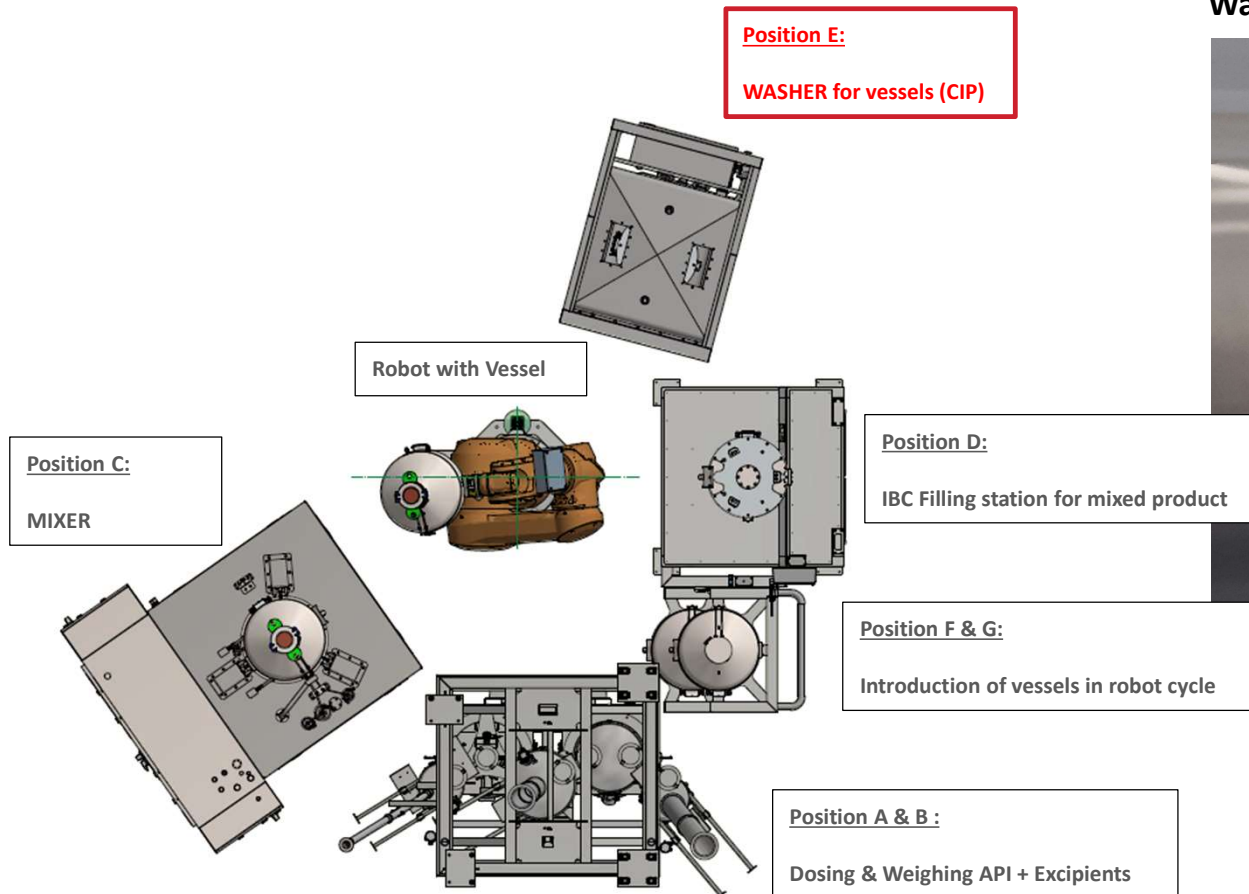

Washer for vessel

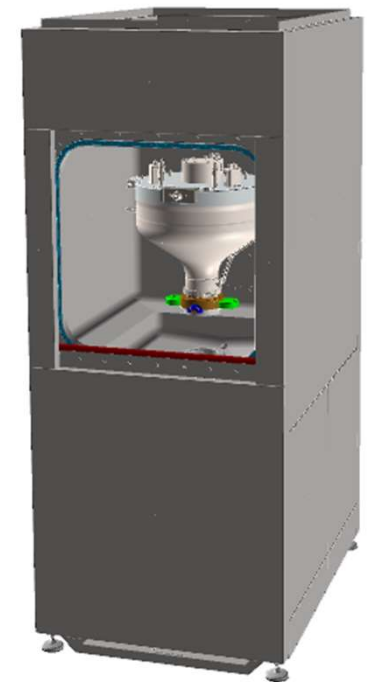
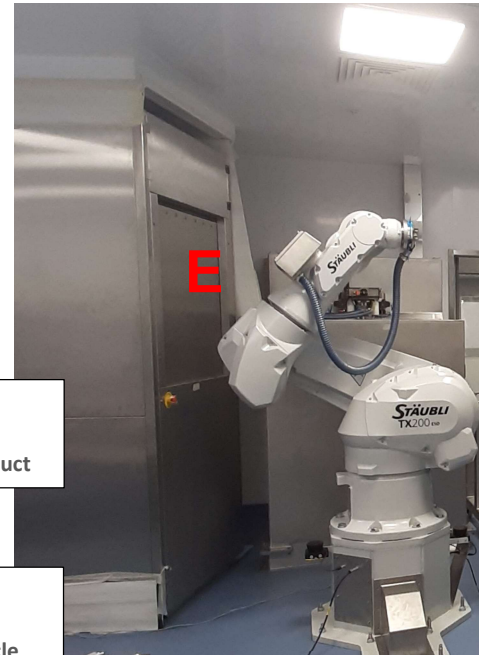

AZO Robot application (API Production)



Introduction of vessels in cycle

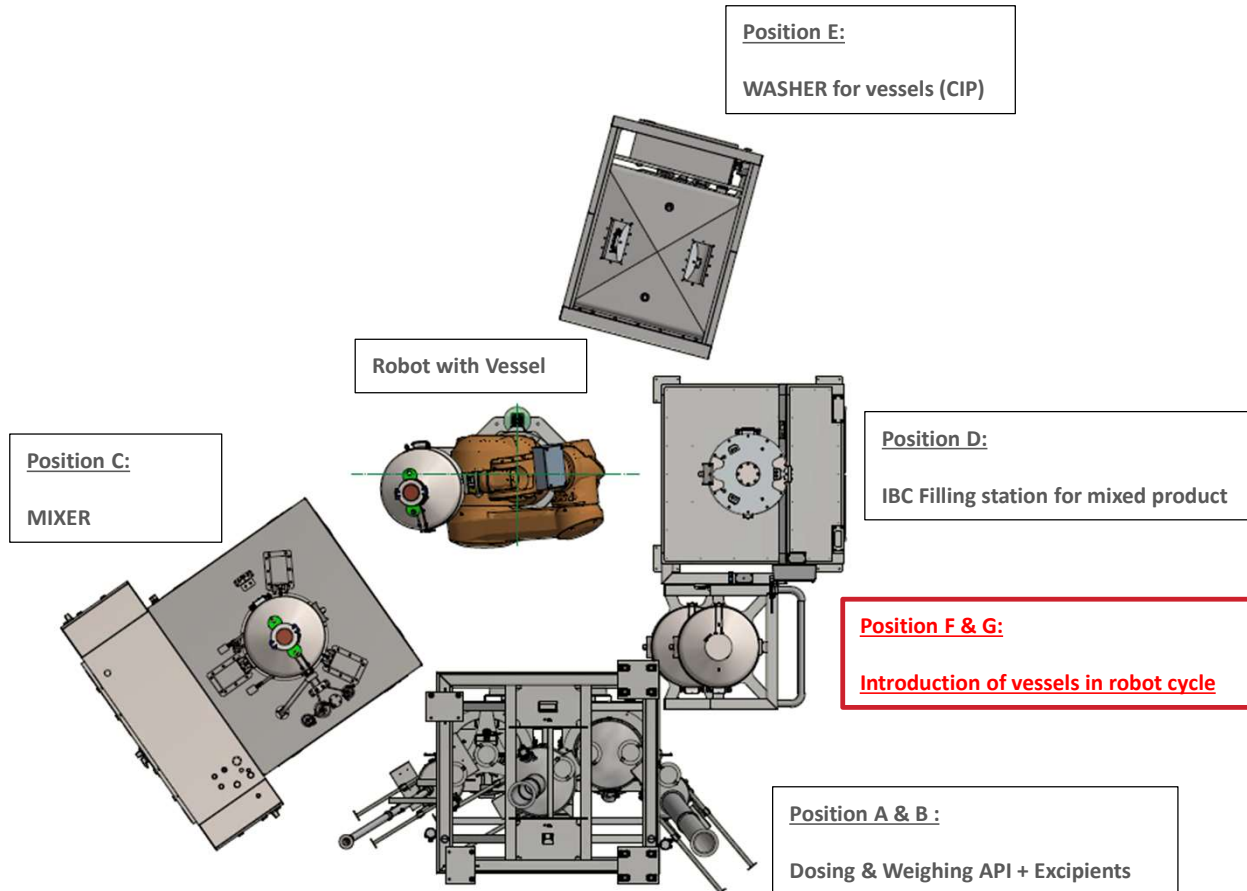

AZO Robot application (API Production)



Improved ergonomics

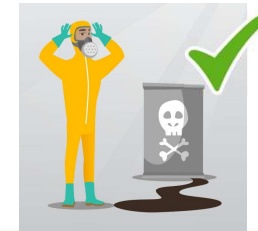

Containment & ATEX requirements



High precision weighing



Batch integrity (CIP)



Batch traceability

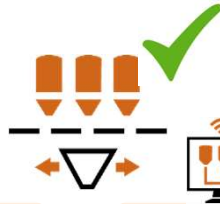

Automated production 24/7 availability



Validated system GMP compliant software





We Love Ingredients.

Thank you for you attention !